

DUPLEX ANAESTHETIC GAS SCAVENGING PLANT



Description

Anaesthetic gas scavenging system (AGSS) plants are designed to provide a safer working environment for the medical personnel by the removal of the waste gases that are produced during anaesthesia and from the surrounding environment.

Duplex AGSS plants comprise of two die cast aluminium side channel blowers complete with electrical controls, pressure sensor, relief valve and drain flasks, all pre-piped, pre-wired and factory tested.

The duplex plant control panel incorporates a duty pump selector and indicators to identify the plant status. The standby pump is activated automatically upon high demand or the failure of the duty pump.

Duplex units incorporate non-return valves to enable the maintenance of one pump whilst the other pump is in service.

Pumps are available to suit single phase or three phase electrical supplies.

Remote switches are available to enable control of the AGSS plant from within the department served and to indicate the status of the plant. Relay contacts to allow monitoring of plant by BMS systems can be supplied if required.

Designed to meet the requirements of;

- **HTM 2022** **Medical Gas Pipeline Systems.**
- **BS 6834** **Active anaesthetic gas scavenging systems.**
- **BS EN 737-2** **Anaesthetic gas scavenging disposal systems – basic requirements.**



ISO 9001 / ISO 13485

CE 0473

Phoenix Pipeline Products Limited.

Unit 8, McKenzie Industrial Park,
Bird Hall Lane,
Stockport,
U.K., SK3 0SB

Tel No.: 44 (0) 161 428 7200
Fax No.: 44 (0) 161 428 7010
www.p3-phoenix.com
Email: info@p3-phoenix.com

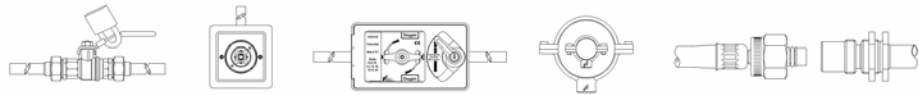

DUPLEX ANAESTHETIC GAS SCAVENGING PLANT

Technical Details

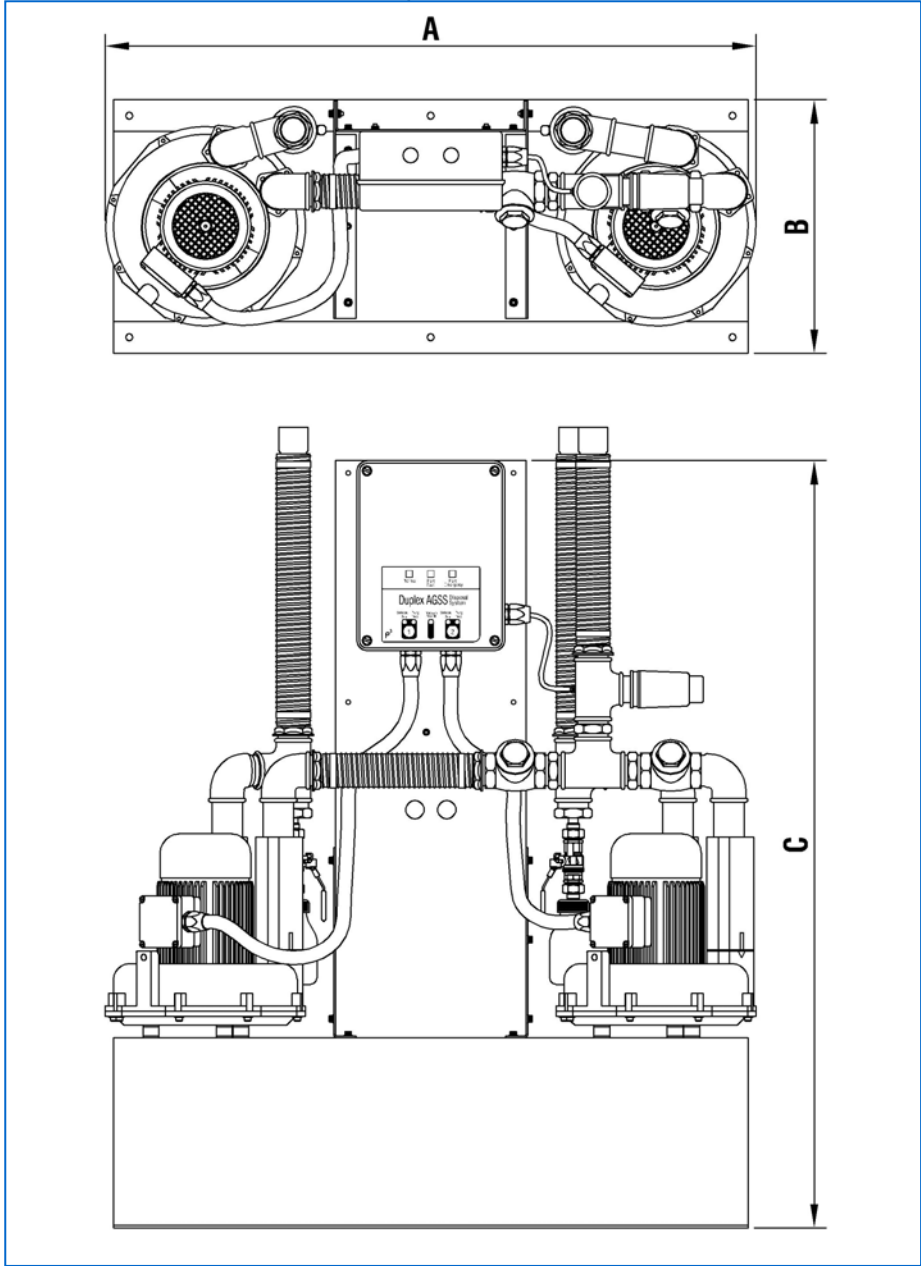

Ordering Information				
Model No.	150.3	150.6	150.10	150.20
<i>Performance</i>				
Flow l/m @ 150 mbar	390	780	1400	2600
No. of Outlets	3	6	10	20
Max Vacuum mbar	165	165	180	230
<i>Electrical Details</i>				
Output kW	0.85	0.85	1.3	2.2
Phase	3	3	3	3
Start (A)	15	15	22.8	34.8
Run (A)	2.5	2.5	3.8	5.8
Starter Type	D.O.L.	D.O.L.	D.O.L.	D.O.L.
Fuse (A)	6	6	10	16
<i>Size & Weight</i>				
Dim A (mm)	1000	1000	1050	1100
Dim B (mm)	400	400	400	400
Dim C (mm)	1200	1200	1200	1200
Weight (kg)	80	80	100	120

All figures Quoted for 415V 50 Hz 3 phase. Single phase, other voltages, frequencies and flow rates available on request.

P3DuplexAGSPlantDSRev1



ISO 9001 / ISO 13485

CE 0473

Phoenix Pipeline Products Limited.

Unit 8, McKenzie Industrial Park,
Bird Hall Lane,
Stockport,
U.K., SK3 0SB

Tel No.: 44 (0) 161 428 7200
Fax No.: 44 (0) 161 428 7010
www.p3-phoenix.com
Email: info@p3-phoenix.com