

## **EMERGENCY STANDBY MANIFOLDS**

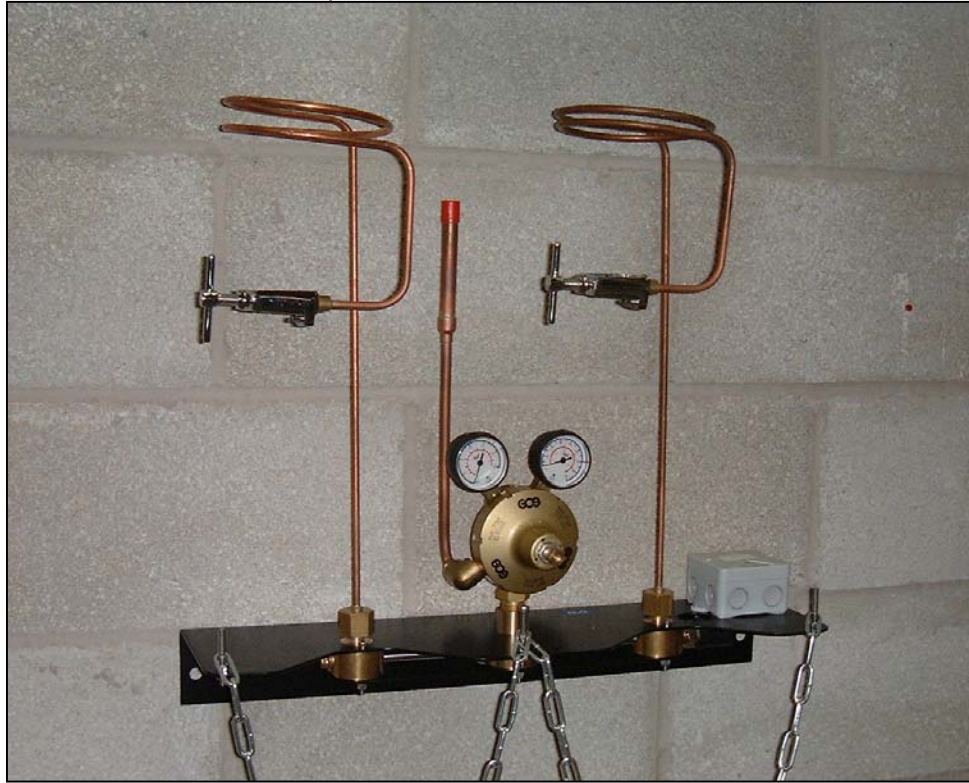

### **Description**

**Emergency Standby Manifolds (ESM) comprise a pressure regulator, 2 x 1 manifold header & rack, tailpipes, a cylinder contents pressure switch, an isolation valve and a pressure relief valve.**

**The ESM is for use with a manifold installation to provide a back-up supply whilst maintenance is being carried out to, or failure of, the main supply manifold.**

**Manifolds are available for oxygen, nitrous oxide, 50% oxygen/50% nitrous oxide mixture and compressed air.**

**An isolation and pressure relief valve assembly is provided with copper stub pipes for on site copper to copper joints to the hospital distribution pipeline and exhaust pipeline.**

**A non return valve is incorporated into each point where the tailpipe connects into the header to prevent a whole bank of cylinders becoming depleted in the event of a cylinder being disconnected or a tailpipe rupture.**

**Tailpipes are available with pin-index or bull nose cylinder connections.**

### **Designed to meet the requirements of;**

- **HTM 2022**                      **Medical Gas Pipeline Systems.**
- **C11**                              **NHS Model Engineering Specification – Medical Gases.**



**CE 0473**

**ISO 9001 / EN 46001**

### ***Phoenix Pipeline Products Limited.***

Unit 8, McKenzie Industrial Park,  
Bird Hall Lane,  
Stockport,  
U.K., SK3 0SB

Tel No.: 44 (0) 161 428 7200  
Fax No.: 44 (0) 161 428 7010  
[www.p3-phoenix.com](http://www.p3-phoenix.com)  
Email: [info@p3-phoenix.com](mailto:info@p3-phoenix.com)

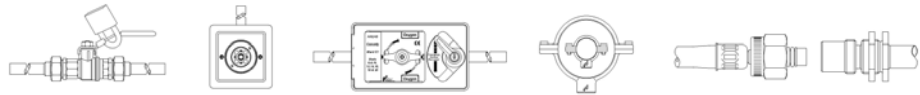

**EMERGENCY STANDBY MANIFOLDS**

**Technical Details**

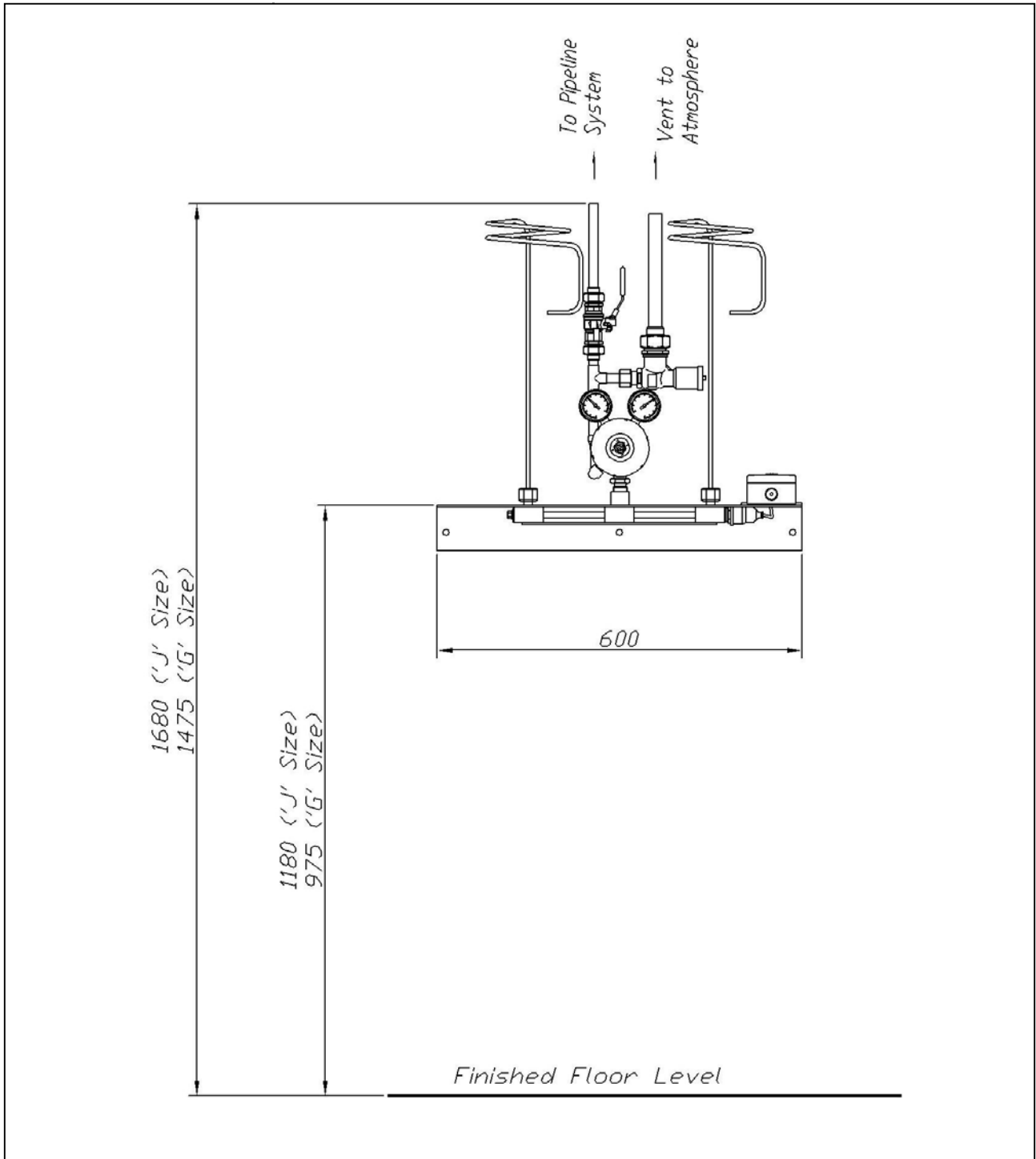

**CE 0473**

**ISO 9001 / EN 46001**

**Phoenix Pipeline Products Limited.**

Unit 8, McKenzie Industrial Park,  
Bird Hall Lane,  
Stockport,  
U.K., SK3 0SB

Tel No.: 44 (0) 161 428 7200  
Fax No.: 44 (0) 161 428 7010  
[www.p3-phoenix.com](http://www.p3-phoenix.com)  
Email: [info@p3-phoenix.com](mailto:info@p3-phoenix.com)